



GRINDING WHEEL



ABOUT US

Was established in 2002.

We are the expert trading company who has more 20 years of experience in Diamond Tool. We trade and import Diamond Tool, Grinding, Polishing, Drill, Cutting Wheel and others from German, Italy, Korea, and China. With over 20 years experiences in Diamond and CBN tools for grinding, polishing and dressing, we comprehend what you need in your business.

COMPONENT

MESH SIZE

1. DIAMOND

- D/SD/SDC
- CBN

2. BONDING

- Resin Bond
- Vitrified Bond
- Metal Bond
- Electroplate

Chart 01

FEPA	ANSI
Grit Designation	US Standard Mesh
D/B 251	60/70
D/B 213	70/80
D/B 181	80/100
D/B 151	100/120
D/B 126	120/140
D/B 107	140/170
D/B 91	170/200
D/B 76	200/230
D/B 64	230/270
D/B 54	270/325
D/B 46	325/400
D/B 40	400/500
D/B 30	500/600
D/B 25	800
D/B 20	1000
D/B 15	1200
D/B 10	1600

Chart 02

Grain Size (um)	ANSI US Standard Micron
50	400
45	500
35	600
30	700
25	800
20	1000
17	1100
15	1200
12.5	1400
11	1500
10	1600
9	1800
7.5	2200
6	3000
5	5000
4	6000
3	8000
2.5	10000
2	12000
1	14000
0.5	28000

Chart 03

Grit Size(mesh)	Ra(um)
80	0.55-0.75
100	0.40-0.55
120	0.35-0.40
150	0.30-0.35
180	0.25-0.30
220	0.22-0.25
240	0.18-0.22
320	0.17-0.18
400	0.14-0.18
500	0.14-0.15
600	0.12-0.15
800	0.07-0.12
1200	0.05-0.10
1500	0.025-0.05

MATERIALS TO BE GROUND



Resin Bond Diamond & CBN Wheel

Our Products

Resin Bond Diamond & CBN Wheel

Resin Bond Diamond/CBN grinding wheels feature of good self-sharpening, sharp cutting, high efficiency, low roughness of workpiece surface, few heat generating and no burning.

The Resin Bond Diamond grinding wheels

For machining tungsten carbide, ceramic materials, magnetic materials, silicon materials, thermal spraying alloy materials etc.

The Resin Bond CBN grinding wheels

For machining High speed steel, cast iron etc.



Electroplated Diamond & CBN tools

Electroplated Diamond & CBN tools are featured with free-faster cutting, non-truing and dressing, less heating due to the diamond particles protruding from the surface.

Diamond plated products are usually a single layer of diamonds highly concentrated, and held on by a tough, durable nickel alloy. This high concentration enables plated products to retain their original shape and dimensions throughout its working life.



Vitrified Diamond CBN Wheel

For PCD & PCBN inserts

With special vitrified bond, E-Grind created a high efficient diamond wheels suitable for sharpening PCD/PCBN insert.

For Camshaft, crankshaft and cylindrical grinding

Vitrified bond CBN wheels are used for grinding the automobile camshafts, crankshafts and cylinder in air-compressor industry.

For Internal Grinding

vitrified CBN inner grinding wheel are widely used for grooving vane pump rotors and synchromesh ball-joints, etc, as well as for forming injection parts.



Metal Bond Diamond & CBN Grinding Wheel

Metal Bonded Diamond / CBN Grinding Wheel is with high efficiency, good self-sharpening, high stock removal, good form remaining and good anti-wearing ability.

Metal Bond Diamond Wheel

Used for machining quartz crystal, tungsten carbide, ceramic, glass, composite, sapphire, ferrite, refractory, thermal spraying material and so on.

Metal Bond CBN Wheel

Used for machining HSS, tool steel, stainless steel, mold steel and titanium alloy etc.

WHEEL's standard shape

1A1

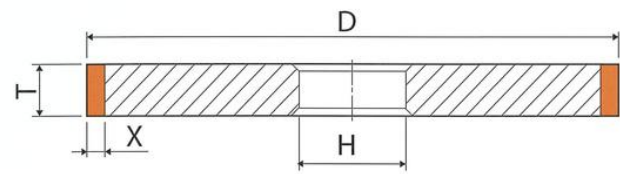

1A8

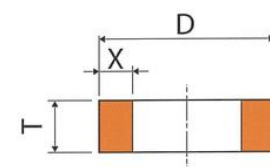

1A1R

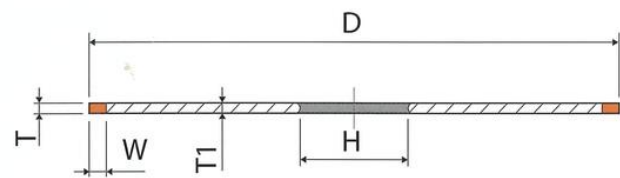

1E1

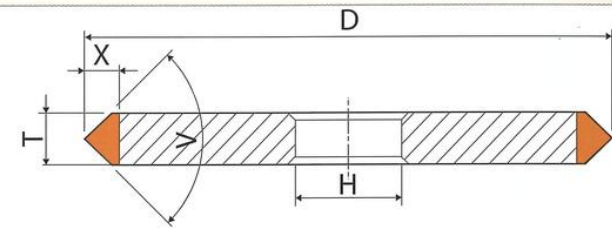

1EE1

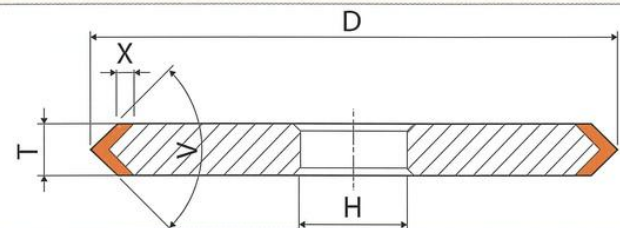

1V1

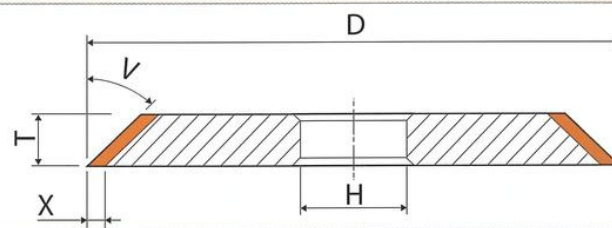

1E6Q

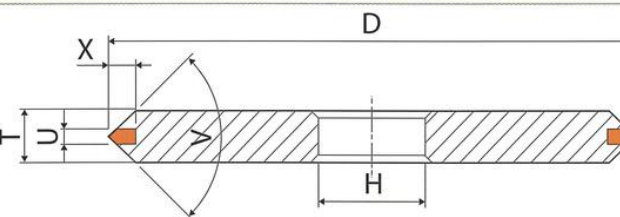

1FF1

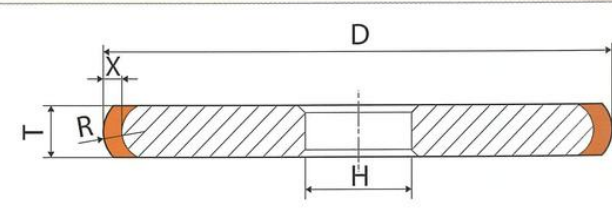

2A2T

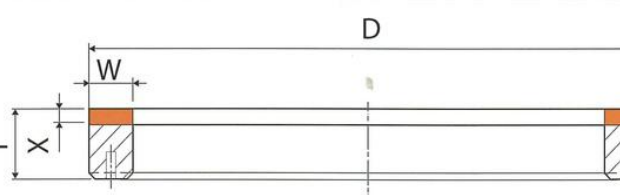

3A1

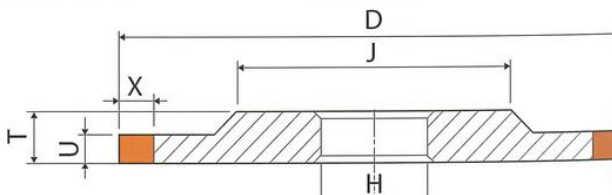

4A2

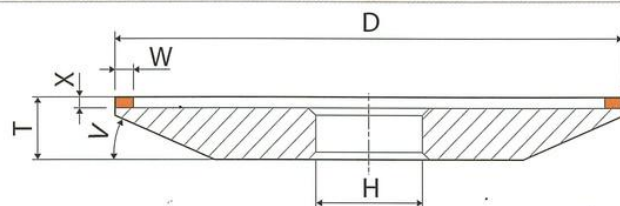

4B2

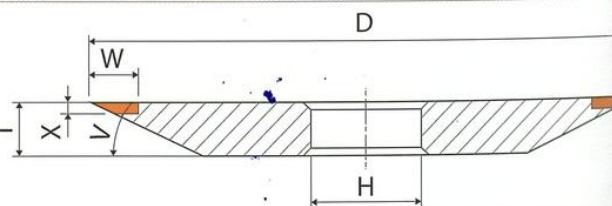

WHEEL'S standard shape

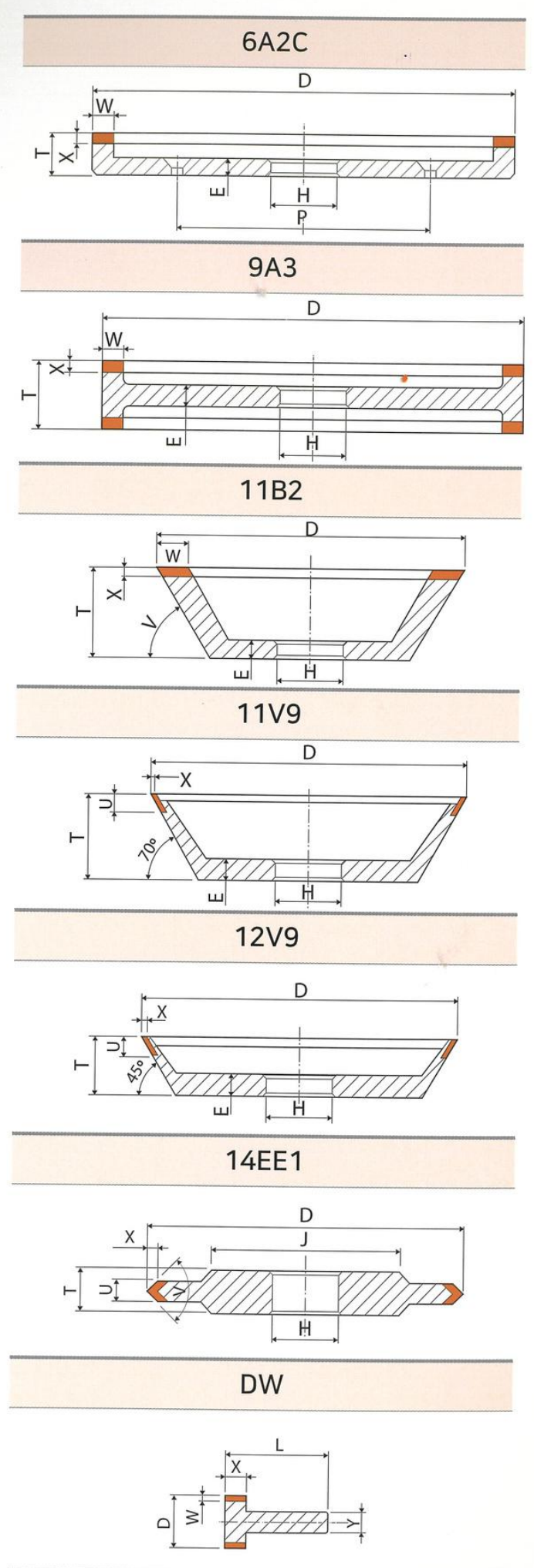
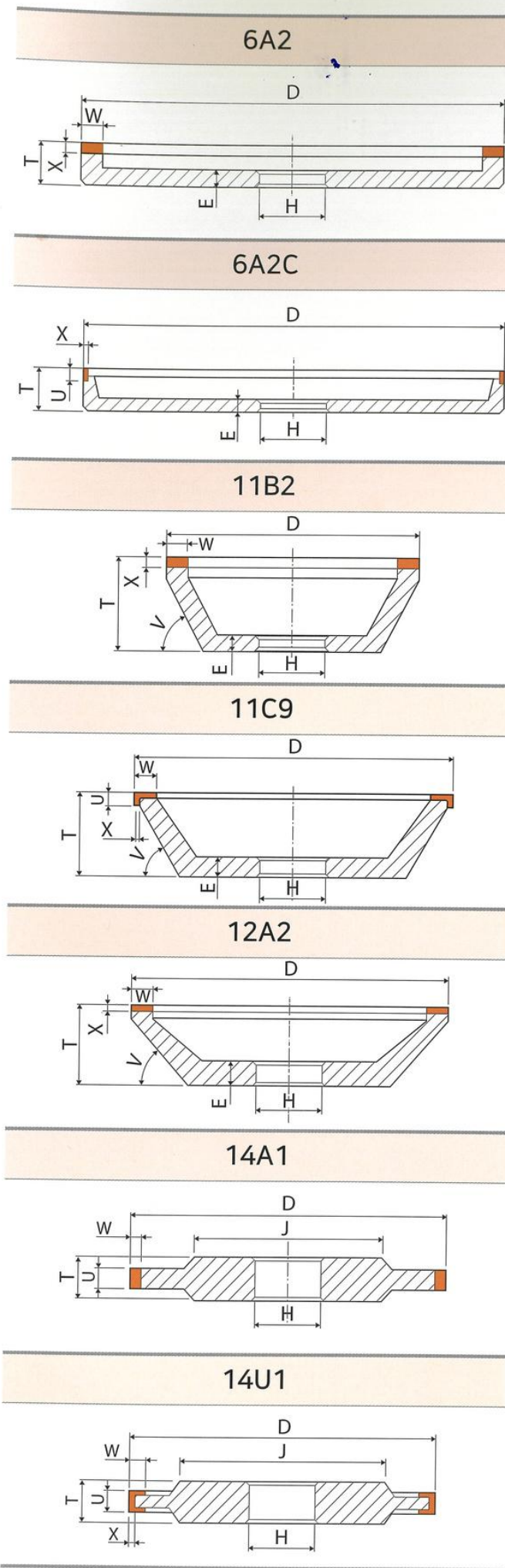

WHEELI'S
standard
shape

THANG YOU



 02-539-2513-4

 www.spbillion.com

 info@spbillion.com

